



D&P Custom Lights & Wiring Systems, Inc.
 900 63rd Avenue North
 Nashville, TN 37209
 Tel: 615-350-7800
 Fax: 615-350-8310

E-mail: Carla@dandpcustomlights.com
 Website: www.dandpcustomlights.com

Q&A with Harley Davidson Case Study

[Harley-Davidson](http://www.harley-davidson.com), the most famous motorcycle manufacturer in the world, is well-known for their fully customizable motorcycles.

Every year Harley-Davidson welcomes thousands of people to their Annual Dealer Meeting, held in 2014 at the Gaylord Opryland Resort & Convention Center in Nashville, TN. When their go-to vendor couldn't produce the sign they needed for the lounge area, they were referred to [D&P Custom Lights & Wiring Systems, Inc.](http://www.dandpcustomlights.com) to get the sign made quickly and effectively. With one week's notice, D&P's design & engineering team team got to work fast on a drawing and quote for them, and had the custom sign manufactured and delivered by the first day of set up.

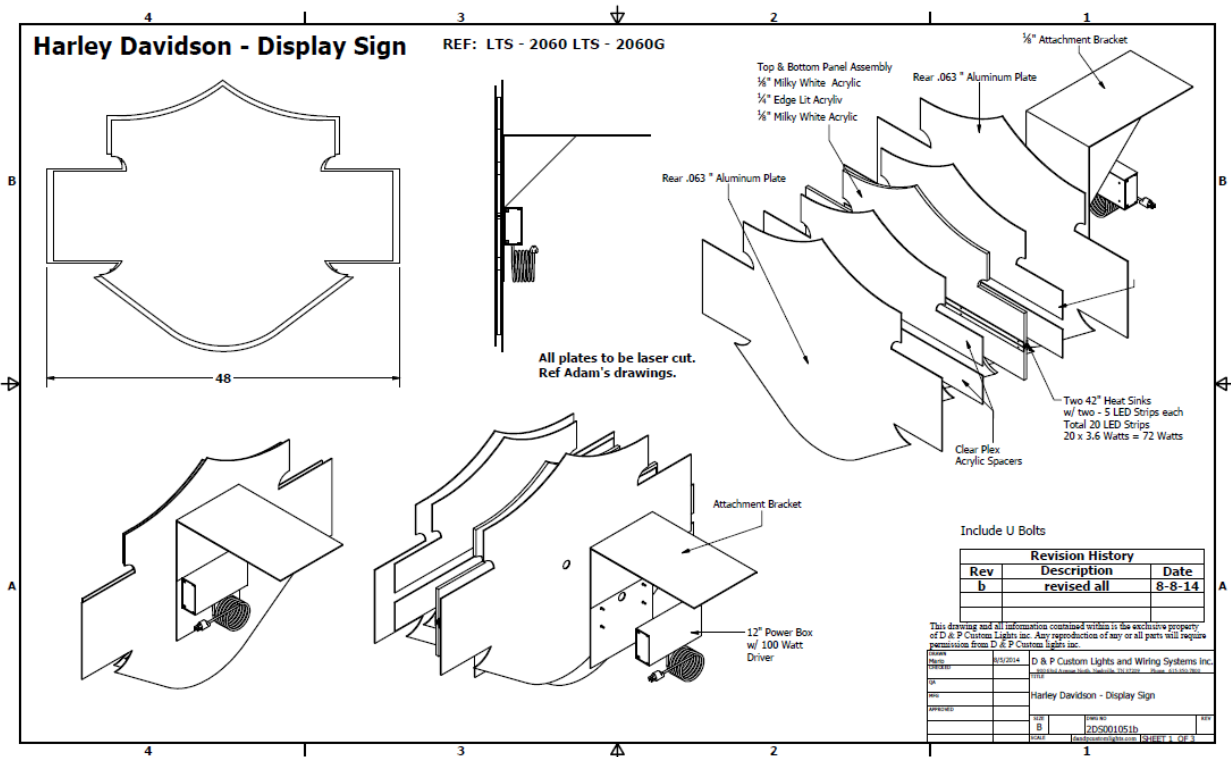

In September 2014 we had a chance to do a Q&A with Denise Mosey, Events Lead (General Merchandise) at Harley-Davidson, about her experience working with D&P Custom Lights. Here is what she had to share:

Q: What prompted you to seek D&P's services?

A: "We were referred by another vendor that could not produce what we needed."

Q: What situation or problem did you need to solve?

A: "We needed a lighted neon-like sign in the shape of our brand's logo."

Q: Why did you specifically select D&P for this project?

A: "We were referred, but after speaking with Neil I realized that you all were perfect for the project we needed completed."

Q: What made you believe that D&P was the best for achieving your desired result?

A: "Neil was great and talked to me to really understand my needs. He was able to take my vision and create it spot on."



Q: How did you benefit from working with D&P?

A: “The sign was amazing and it was very impactful in the area that it was used! We will be able to use it at other events.”

Q: What are the two most significant improvements that have resulted from your work with D&P?

A: “Selecting vendors can be challenging when you are working remotely. D&P managed that incredibly well and could produce what we wanted based on a very focused discussion.”

Q: What exactly did D&P do to contribute to the outcome you wanted?

A: “They produced a beautiful sign in a short amount of time within budget. You cannot ask for more than that.”

Q: Describe why you feel that working with D&P was successful.

A: “Neil was easy-going, understood my needs and asked questions when needed.”

Q: In the future, what type of businesses would most benefit from working with D&P?

A: “I would come back to have additional signage made any time based on this experience. I loved the sign so much I would not mind having something done on a personal level for my own home.”

Q: If a potential client was on the fence about whether to work with D&P or not, what would you say to them?

A: “You will not be disappointed and they will deliver, and you will get exactly what you want and need.”

[D&P Custom Lights & Wiring Systems, Inc.](#) would like to help you create a well-designed, efficient and inviting retail or shopping environment! Call 1.800.251.2200 or [e-mail](#) us today to get started!

D&P Custom Lights & Wiring Systems, Inc.
“Bright Ideas for Custom Power Solutions!™”

Follow Us:

